

**MCB 5.0 & earlier Control Board
(Board you are replacing)**

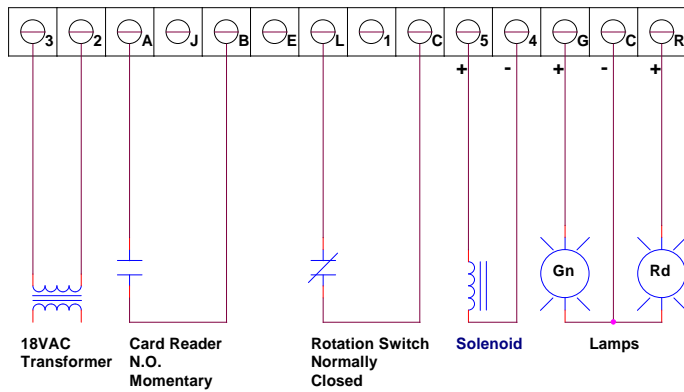

TCB 6.0, 6.1 & 6.2 Control Board (New Board)

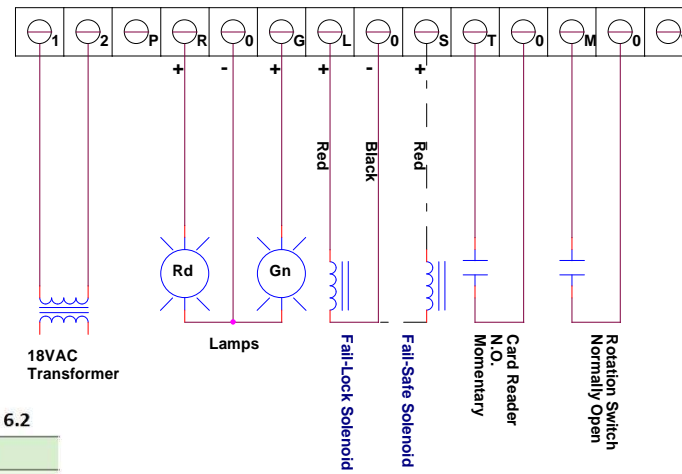

**Turnstile Control Board
Model TCB 6.1 - 6.2**

MCB 5.0 can be identified with the terminal markings shown above. Earlier versions of this board will be somewhat similar and may have a different terminal layout. In most cases this circuit board will have option connectors J11 & J21 for daughter boards/piggyback boards. In addition there may be configuration jumpers JP1, JP2 and JP3, depending on version.

This older/obsolete design required the rotation microswitch to be "Normally Closed"

	MCB 3 Thru 5.0	TCB 6.0 – 6.2
18 VAC	3 & 2	1 & 2
Red Lamp	R & C	R & 0
Green Lamp	G & C	G & 0
Card Reader	A & B	T & 0
Rotation Sw.	L & C	M & 0
FL Solenoid	5 & 4	L & 0
FS Solenoid	5 & 4	S & 0

This upgraded Turnstile Control Board has the same mounting footprint as earlier versions. There are no daughter boards nor configuration jumpers. Both "Pulse" and "Timer" features are standard.

Mode configuration is done by wiring the solenoid to the appropriate terminals. For Fail-Lock operation, connect the solenoid to terminals L & 0. For Fail-Safe operation, connect the solenoid to terminals S & 0.

This improved design requires the rotation microswitch to be "Normally Open" You must move the wire currently on the NC terminals of the microswitch to the NO terminals of the microswitch.

Please note the the above wiring diagram indicates terminal polarity. If you are using LED lamps then be sure to observe proper polarity. If you are using polarity sensitive solenoids (usually indicated by red & black wires), also be aware of polarity wiring. Non-polarized solenoids generally have the same color wires. Terminal 0 is always negative.

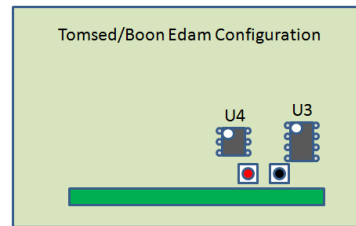
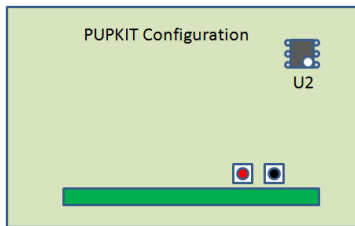

The TCB 6.1 & 6.2 controller board can be configured for different applications. When not specifically specified, The TCB is shipped in the Tomsed/Boon Edam configuration shown on the right. Should you need to re-configure your TCB for use with a PUPKIT, carefully remove the integrated circuit chips U4 & U3 from their sockets. This can be done by inserting a pocket screwdriver blade between the chip and socket at either end. Insert the 6 pin chip removed from U4 in position U2 with the index dot facing down as shown at the left. The chip removed from U3 is not needed.

TCB 6.2 Pushbuttons

Tomsed/Boon Edam configuration: The red pushbutton simulates a card reader signal by shorting terminals T & 0. The black pushbutton simulates a rotation microswitch reset by shorting terminals M & 0. Pukpit configuration: The red pushbutton performs a direct activation of the on-board relay by shorting terminals V & 0.

**Rotation Microswitch
Terminal Identification**

IMPORTANT
Move wire on rotation microswitch from NC to NO

